



創唯實業有限公司

PLASTRONIC TECHNOLOGY CO., LTD.

TEL : 886-2-2276-3375

www.loadcell.com.tw

E-mail: plastronictech@gmail.com

FAX : 886-2-2276-3557

www.plastronic.com.tw

新北市24252新莊區化成路398巷13號

No.13, Lane 398, Huacheng Rd., Xinzhuang Dist., New Taipei City 24252, Taiwan

DC7-SS

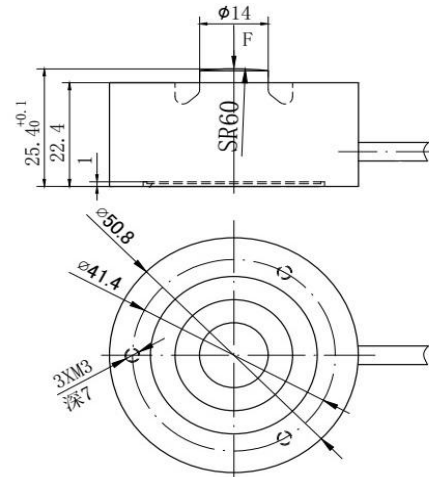

應用：塑膠成型機

Applications: Plastic injection machine

技術規格 Specification

額定荷重	Rated Capacities	0.5,1,2,3,5(t),15K (lb)
額定輸出	Rated Output	2.0 mV/V ± 1%
非線性	Non-linearity	< 0.5% F.S.
輸出溫度影響	Temperature Effect On Output	< 0.01 % F.S / °F
零點溫度影響	Temperature Effect On Zero	< 0.01 % F.S / °F
零點平衡	Zero Balance	< 1% mV/V
輸入阻抗	Input Impedance	700 ± 50 Ω
輸出阻抗	Output Impedance	700 ± 5 Ω
絕緣阻抗	Insulation Impedance	≥5000 MΩ at 50Vdc
安全過載率	Safe Overload	150 %F.S.
極限過載率	Ultimate Overload	200 %F.S.
工作溫度範圍	Operating Temperature Range	-20~60 °C
建議工作電壓	Recommended Excitation	5~12 VDC
最大工作電壓	Maximum Excitation	15 VDC
材質	Construction	不鏽鋼 Stainless Steel
防水等級	Protection Class	IP65
電纜線	Cable	φ4×2m
建議台面尺寸	Recommended Platform Size	

接線方式 Mode of Connection

紅：電源+，黑：電源-，綠：信號+，白：信號-
Red (EXC+) ,Black (EXC-) ,Green (SIG+) ,White (SIG-)